



INSTALLATION GUIDE

Ultrasky[®]
LANTERN by Ultraframe

ULTRASKY LANTERN

NOVEMBER 2017 | V4



Thank you for choosing the Ultraskey Lantern product. This guide is designed to make fitting as straightforward as possible.

Before you commence installation of the lantern, please take a moment to read the rest of this guide.

Any feedback - positive or negative - is welcomed so we can make our systems even better.

This guide is written on the basis that the surveyor has undertaken correct checks for the capability / structural performance of any existing flatroof to verify it is fit for purpose. A timber kerb and weatherproofing materials for the deck/kerb interface are not provided.

Please contact the Ultraframe Tech Support Team on 01200 452 918 or email techsupport@ultraframe.co.uk

CONTENTS

Overview / Tools / Materials handling	p2-3
System overview	p4
Component identity list	p5-6
Installation sequence	p7-12
PVCu roof vent installation	p12-13
Cleaning and maintenance - aluminium	p14

General points

Care should be taken when handling components that are seen by the homeowner, as surfaces may be scratched if not handled with care. Choose a suitable area for unpacking the components and always check them before fitting. Any claims for missing or damaged parts are only accepted in line with our standard terms and conditions of sale.

Health & safety

Site safety is paramount. The Construction (Design & Management) Regulations 2015 apply to the whole construction process, on all construction projects from concept through to completion. Compliance is required to ensure construction projects are carried out in a way that secures health and safety. The installation company shall be responsible for the safety of all of the fitting team, the customer and members of the public.

The Surveyor should have carried out a risk assessment to reduce risk on site and this should have been discussed with you prior to starting.

Please use safe working platforms and ladders that comply with BS EN 131. Always use equipment in line with manufacturers recommendations. Personal Protective Equipment –such as goggles, mask and ear defenders – should be used when, for example, grinding out for the flashing.

Careful consideration should be given to the safe disposal of all packaging which can be readily recycled.

Product

The lantern kit is supplied with a location plan. The location plan is used to match individual components to their respective position on the roof.

The majority of aluminium and PVCu components contain identification codes, usually by inkjetting or labelling – should you need to re-order a part this should help. (See component list on p6-7)

Sealing

It is important to use the correct sealant when sealing the roof. Always use MS Polymer sealant such as Rotabond 2000 on self cleaning glass.

The flat roof structure

Check the existing structure is sound and structurally fit for purpose. Check the opening is 'square' and the flat roof deck is level. A timber kerb of 150 x 70mm width should be used onto which is attached the lantern.

Technical Support

Tel: 01200 452 918

Email: techsupport@ultraframe.co.uk

TOOLS REQUIRED



8, 10, 13mm Socket Spanner



Deadblow Hammer or White Rubber Mallet



No. 2 Pozi-drive Bit



Drill/Screwdriver



Gasket Shears/Snips



4.5mm Drill Bit
10mm Drill Bit



Spirit Level (magnetic useful for internals)



Tape Measure



Box cutter or Stanley knife

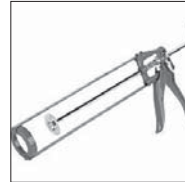

Sealant Gun



Support Prop

THERE ARE SOME MATERIALS YOU NEED TO SUPPLY: EG. PLASTERBOARD, 150 X 70MM TIMBER KERB, FIXINGS TO HOLD ALUMINIUM EAVES BEAM TO TIMBER KERB



MS Polymer

- Self cleaning glass
- Use the correct sealant on glazing

HANDLING ALUMINIUM PRODUCTS

PAINTED ALUMINIUM PRODUCTS - PLEASE NOTE

All paints will 'chalk' to some extent and there will be a reduction in gloss level over time. (See Cleaning and Maintenance guidelines see p13)

QUALITY EXPECTATIONS ON INSTALLATION.

Appearance: This is assessed based on the selection of the 'significant' (primary) surface. From a distance of 3m, stand at an oblique angle of 60degree and then defects such as blisters, runs, pin holes etc should NOT be seen.

Colour and gloss: Viewed from 5m, the coating must be of even colour and gloss with good coverage.



If storing in warehouse racking or on rails/roof racks, take care to support the products and do not over tension straps and ropes. When opening sealed packs, use a special box knife opener.

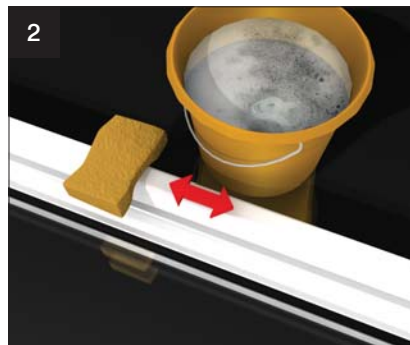

Grease marks, dirt and mastic spillage may be removed using soapy water.

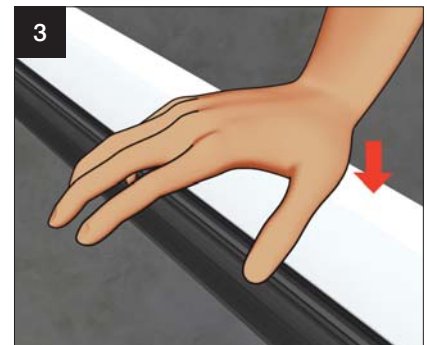

Take care when fitting aluminium products to not use excessive force.

SYSTEM OVERVIEW



ULTRASKY LANTERN

- 1 High performance thermal break
- 2 Patented thermally insulated aluminium rafter
- 3 Super strong ridge for fewer bars and more light
- 4 Thermally isolating top cap clip
- 5 'Secure-fit' end caps are a further thermal barrier
- 6 Thermally broken eaves rail
- 7 Superior 25° pitch for elegance and light
- 8 Adjustable reinforced stopper to prevent glass slipping
- 9 Choice of aluminium or PVCu internal and externals

STRENGTH, WARMTH AND MAXIMUM LIGHT, PERFORMANCE ENGINEERING

Ultrasky's Stormshield Protection System includes:

- 1 Waterproof glazing compression trims
- 2 Ridge end weathering shields
- 3 Secure fit radius end covers





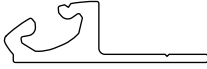

Ultrasky[®]
LANTERN by Ultraframe

COMPONENT IDENTITY LIST

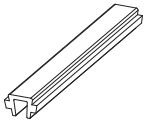
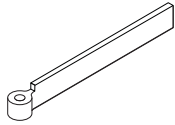
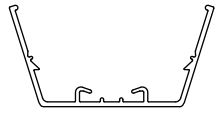
 <p>QORER600M ORANGERY EAVES RAIL 6M MILL</p>	 <p>LAN/6 THERMALLY BROKEN RIDGE</p>	 <p>SPGC/1 TRANSOM/VIC GLAZING BAR (78MM)</p>	 <p>SPTA/1 GEOR HIP GLAZING BAR (HEAVY)</p>	 <p>ATC/25 ALI CLIP FIT BAR CAP TRAN STD 25MM</p>
 <p>LAN/4 ALUMINIUM CLIP FIT BAR CAP GEOR 25MM</p>	 <p>CCA/25 CHAMBERED DOME TRANSOM CAPPING 25MM</p>	 <p>CCG/25 CHAMBERED GEORGIAN CAPPING 25MM</p>	 <p>GBCB600C GLAZING BAR CLADDING 6M WHITE</p>	 <p>PSUB600BL SUPPORT TRIM - BLACK SEALED UNITS</p>
 <p>AGP/25 25MM ALUMINIUM GLAZED END PROFILE</p>	 <p>PCFD400W/24 PVCU END COVER (24MM)</p>	 <p>Q8159/6 WING CLADDING</p>	 <p>AGS305 Q-LON GASKET SEAL T SLOT QEZ376</p>	 <p>Q8201 RETAIN BEAD GASKET 150M</p>
 <p>LAN032BL LANTERN FAB END</p>	 <p>LAN031 LANTERN TRANSOM BRACKET</p>	 <p>LAN035/1 LANTERN EXTERNAL COVER PVCU 2 BAR</p>	 <p>LAN035/2 LANTERN EXTERNAL COVER PVCU 3 BAR</p>	 <p>LAN028/1 EXTERNAL RAD END COVER ALI 2 BAR</p>
 <p>LAN028/2 EXTERNAL RAD END COVER ALI 3 BAR</p>	 <p>LAN030/1 INTERNAL RAD END COVER 2 & 3 WAY</p>	 <p>LAN029 FOAM WEATHERING SHIELD - GLAZING</p>	 <p>LAN036 PRESSED INTERNAL COVER - 2 WAY (OPTIONAL)</p>	 <p>LAN036/2 PRESSED INTERNAL COVER - 3 WAY (OPTIONAL)</p>
 <p>CCTA001 CHAMB DOME ENDCAP</p>	 <p>CCG001 CHAMB GEORG ENDCAP</p>	 <p>DCM001/WV ENDCAP MOTIF (CONCENTRIC)</p>	 <p>KDS001 4.8X25 PZ PAN SLF TAP BS 4174 Z&C</p>	 <p>JRKA004/1 M4 X 12 PZ PAN TRI-LOBAL Z&C</p>
 <p>SHBC001T TWIN BOLT & NUT</p>	 <p>SHBC001S M6 SINGLE BOLT AND NUT</p>	 <p>EBT001 M5 x 12 PZ PAN TRI-LOBAL SCR Z&C</p>	 <p>LANRF001 R/END M6 X 40 POZI PAN HEAD TAPTITESCREW</p>	 <p>LVCC001 ALI TOP CAP/ CLIP</p>

COMPONENT IDENTITY LIST

 <p>JRKA002 JACK RAFTER TENON KIT 15MM</p>	 <p>JRT027 CENTRAL TRANSOM TENON 27MM</p>	 <p>JRKA001/4 CHANNEL INFILL 27MM</p>	 <p>LAN014 BAR UNDERCLADDING CLIP</p>	 <p>LAN/3 ALUMINIUM INTERNAL UNDERCLADDING - HIP</p>
 <p>LAN/2 ALUMINIUM INTERNAL UNDERCLADDING - TRANSOM</p>	 <p>LAN/1 ALUMINIUM INTERNAL RIDGE UNDERCLADDING</p>	 <p>LAN100 FOAM INSULATION (FACTORY INSERTED INTO BAR UNDERCLADDING)</p>	 <p>LANCE600BL ULTRASKY EAVES SLEEVE PVCu</p>	 <p>DSBC600CBL BLACK GLAZING BAR UNDERCLADDING THERMAL SLEEVE</p>
 <p>SHBCB001SL/1</p>	 <p>FLN001</p>			

PRE INSTALLATION

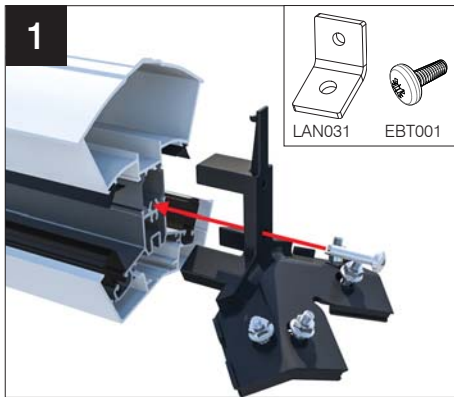

LANRF001 is supplied pre-installed into the bar. Remove and fix radius end (LAN032BL) then replace the screw. If using 3 bar attach LAN031 using EBT001.

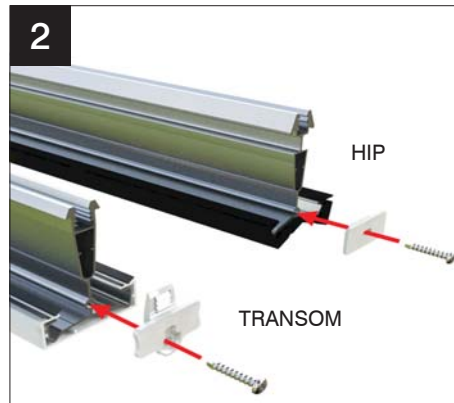

Attach the glazing bar end cap fixing blocks - as access restrictions may prevent easy fixing later. NOTE: These 'snap out' of the end caps when despatched from the factory.

GENERAL INSTALLATION

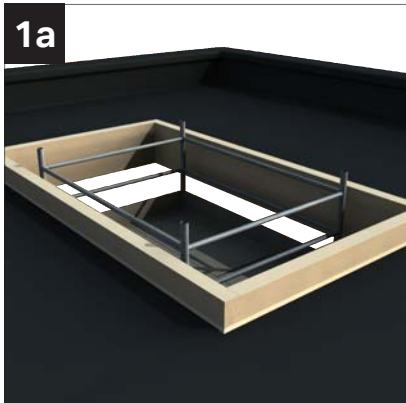

1a
Construct the upstand to the flat roof with minimum of 150mm tall kerb (minimum of 70mm wide). Check that kerb is square by measuring diagonals. Apply membrane as per manufacturers guidelines.

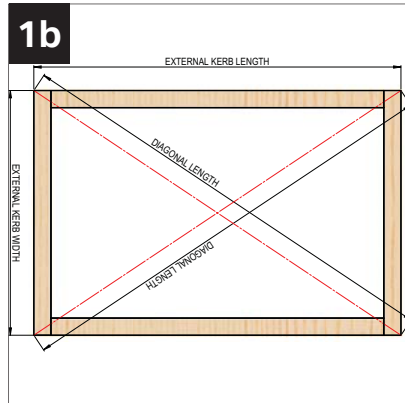

1b
Check diagonal measurements.

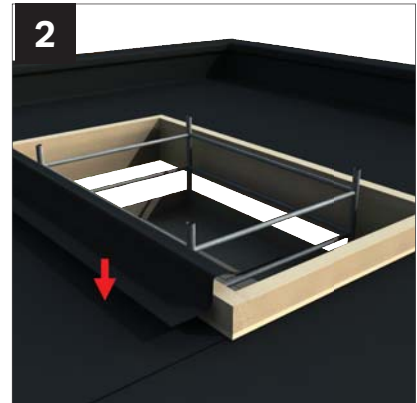

2
Wrap the membrane up the kerb and lap over the top of the kerb ensuring that a watertight finish is achieved.

This is general guidance only - depends upon proprietary system being used.

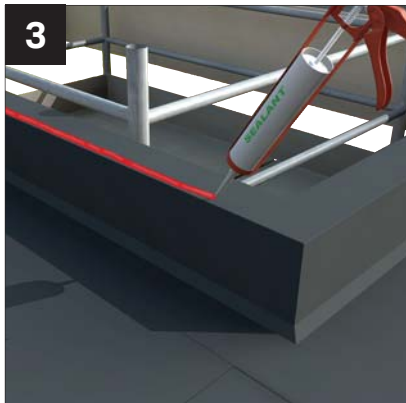

3
Apply a generous, continuous bead of silicone to the outer perimeter of the top surface of the kerb.



4
Pre drill 100mm from each end and drill a minimum of 4 holes at a max of 400mm centres using appropriate clearance drill. Now take the eaves beam/rail and ensure correct number of bolts are slotted into eaves beam/rail.

Minimum of at least 4 screws per eaves beam/rail length.



5
Cross section of timber kerb with eaves beam / rail in position - note flush with outer edge of kerb.

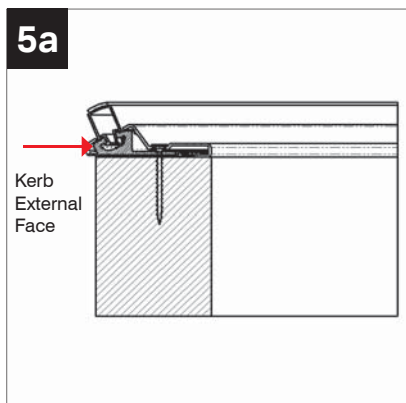

5a
Aluminium eaves beam/rail (not the PVCu sleeve) flush with external face of kerb.

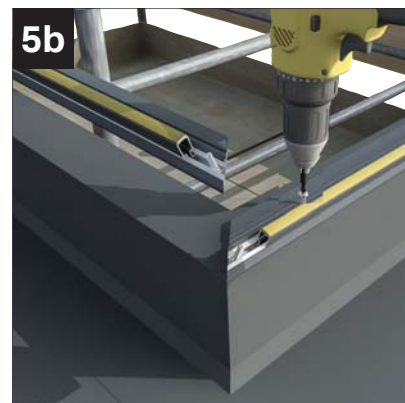

5b
Check the required number of bolts are in the eaves beam/rail. Seal cut ends of eaves. Line up eaves along outer edge of kerb* and screw down using appropriate 5mm x 50mm fixings (not supplied) ensuring good engagement.

*As shown in previous image.

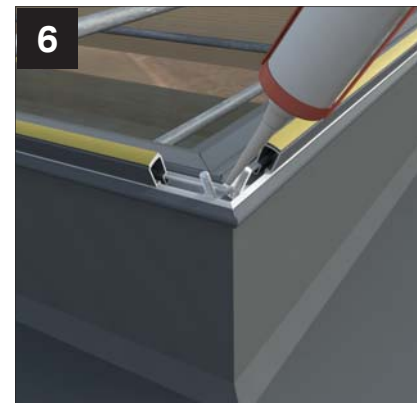

6
Once eaves beam/rail is fitted, silicone corner joints.

GENERAL INSTALLATION

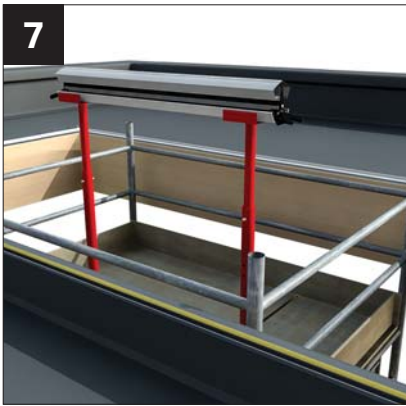

7 Prop ridge in position using suitable supports, centralising between eaves beam sections. (When the ridge features aluminium painted internal finish it will need to be protected whilst supporting).



8 Using nuts and bolts (SHBC001S - found in BURBOX), locate each hip bar and secure to radius end by hand tightening nuts.

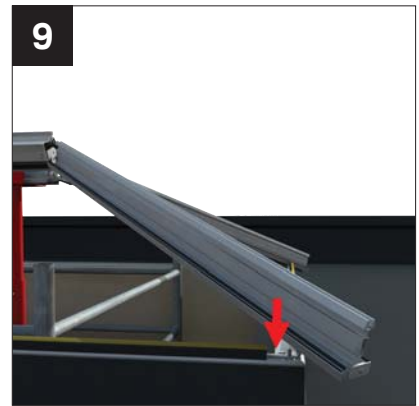

9 Remove nuts on eaves beam. Fit hip bars onto bolts at eaves end and hand tighten nuts.

JACK RAFTERS
- If your project has them

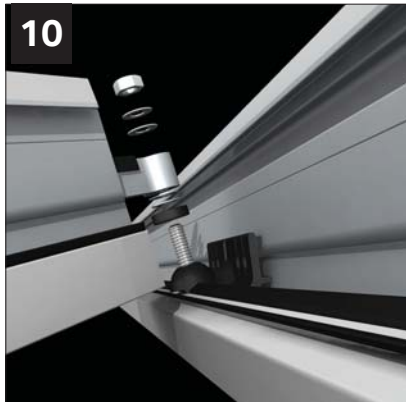

10 Now fit the jack rafters. The 2 part jack rafter kit is already fitted to the hip and jack rafter. Ease back the jack rafter undercladding. Each jack rafter kit is supplied with a number of washers. Trial fit the jack rafter and check that the glazing platforms are level. Adjust if necessary by adding or removing washers between the two part connecting kit, then tighten the nut. **NOTE: If aluminium internal claddings are being used, fit hip internal cladding prior to fitting jack rafters.**

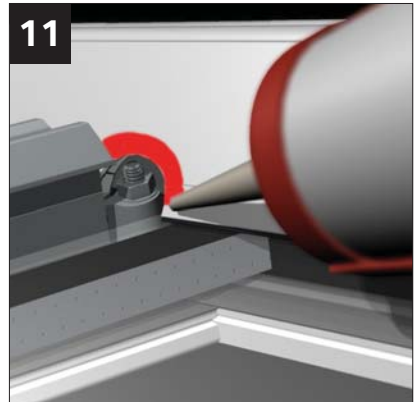

11 Seal around the notched hip bar top cap ready to receive the jack rafter capping.

TRANSOM BARS
- If your project has them



12 Depending upon the lantern size and options requested, fit hub end transom bar and / or side transom bars. If specified on the job, remove nuts from bolts in transom position and fit transom bar over bolts. Re fit nuts and hand tighten. Check that ridge is level and fully tighten nuts on all bars.

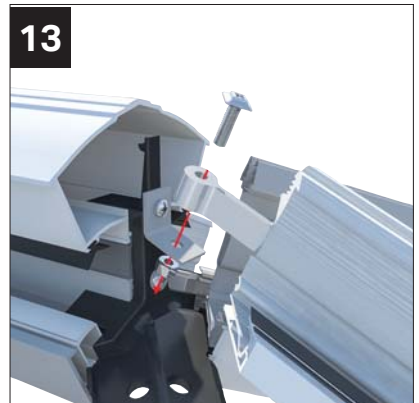

13 When a transom is fitted between hips, lift transom bar sleeved spiggot over bolt, then tighten nut.

FITTING ALUMINIUM INTERNAL CLADDING (IF SPECIFIED)

NOTE: ENSURE RIDGE UNDERCLADDING IS CENTRED ON RIDGE BODY

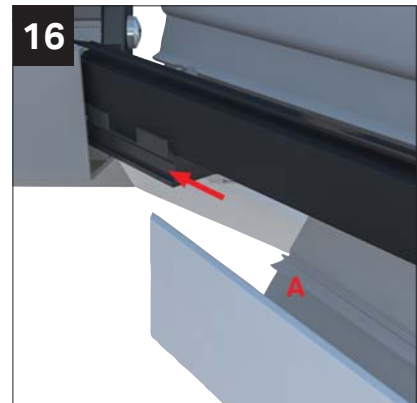
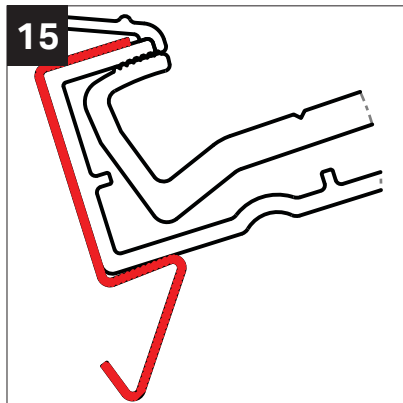

Attach the spring clips (LAN014) to side of the glazing bars.

TRANSOM - 2 clips 50mm from the top of the bar. 2 clips 100mm from the eaves.

HIP - 2 clips 100mm from the eaves.* top of bar locates on ridge end (see step 16). Push the leg in under the gasket and spring around the underside as shown. Ensure the clips are fully pushed on.

Spring clips in position.

Position top of hips into ridge end ensuring they butt up against it. Locate on the lip as shown above.

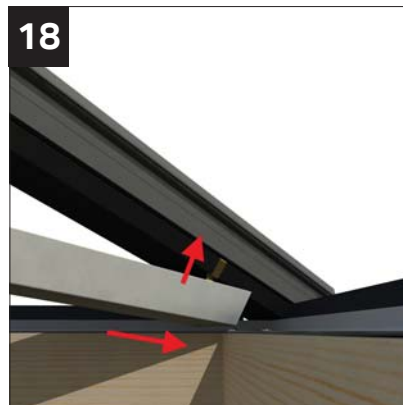
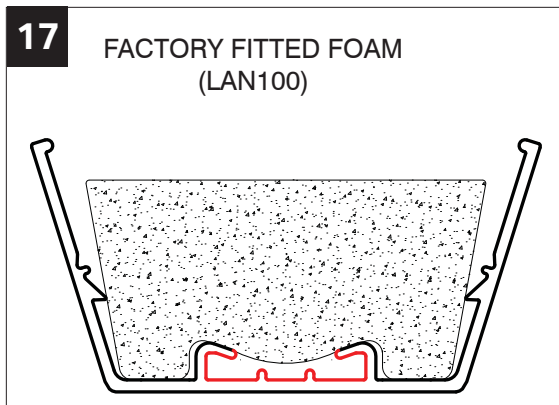

Ensure the foam does not interfere with the clips by pinching it towards the centre of the bar.

At eaves, slide undercladding down towards eaves as far as you can and push onto clips. Hip claddings are asymmetric. Fit with short cut between hips as shown, claddings have red and blue coloured dots attached to indicate position - always use a red and blue dot at each ridge end.

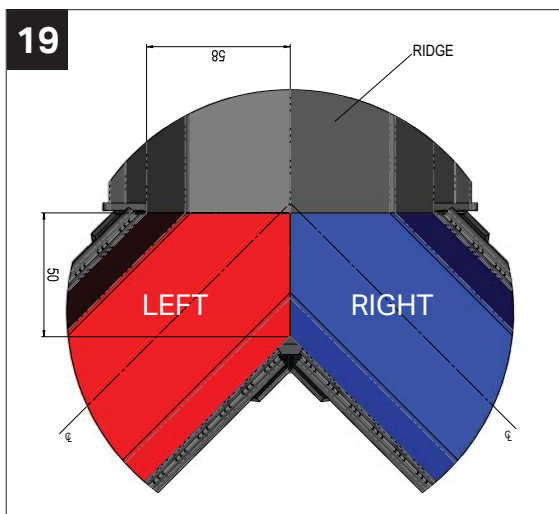

Look up with a 'worms eye view' down the central bar to distinguish left and right.

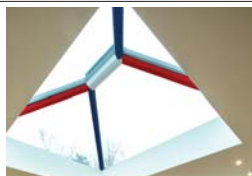

GENERAL INSTALLATION CONTINUED

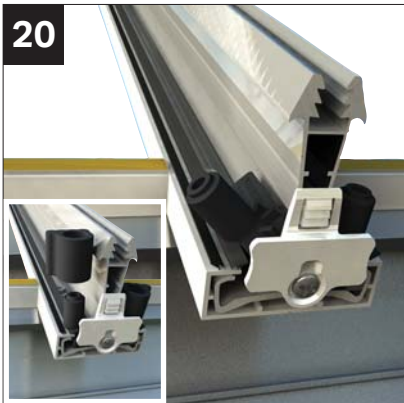

Now move to the glazing stage. Snap off appropriate handed glazing stop (LH shown). Handing marked at base of glazing stop. Line up the rounded edge on base plate next to central web of glazing bar and tuck under gasket side of bar. Rotate glazing stop into position. Push the grommet over the post. Slide assembly down to end of bar.



MS Polymer sealant only on Self cleaning glass

Seal underside of top face of glazing end profile as shown (PVCu version of end profile is shown - if aluminium glazing bar top caps, this end profile is also aluminium).



Peel back a small tab of the protective film on the glazing support from the eaves and the ridge. (ready to be pulled away when the sealed units are finally in position). **DO NOT FULLY REMOVE TAPE YET.**



Lift glass units into place onto the eaves support trim. When fitting units along the ridge, lift the unit slightly and push into the ridge, then lower onto the eaves against the glazing end stops.



Centralise the glazing between the glazing bars. If necessary, pack out on each side. Now fully peel away protective film from glazing support at eaves and ridge and press glazing down firmly. Ensure that glazing end profile sits snugly behind grommet, on the glazing end stop. Now using the fixings provided, screw down into the bar as shown.



Work your way around the roof and fit PVCu glazing bar topcaps.



This stage should have been prepped in the factory. If not take the aluminium top caps and lay them onto a protected surface. Slide clips into each bar - position down from ridge / eaves at a max centre of 100mm and then at 500mm centres (max) inbetween.



Using the heel of your hand, push down on the top cap to engage the clips, working from ridge to eaves. Ensure the rubber gaskets are fully compressed for a watertight seal. **NOTE:** on longer bars it may be necessary to use a soft mallet and timber block.

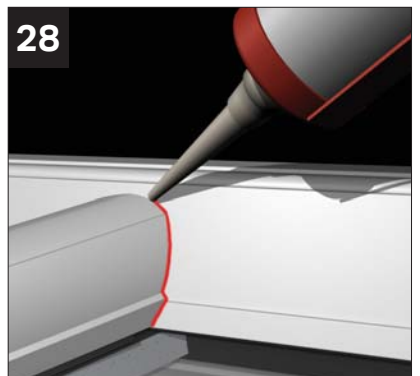

Seal around the joint on the jack rafter capping when complete.

INSTALLATION - HUB END AND END CAPS



1

ENSURE THE GLASS IS CLEAN AND DRY BEFORE FITTING. Peel back protective film from weathering shield and position (adhesive face down) on glass, locating around the ridge and the hip bars. Press down firmly.

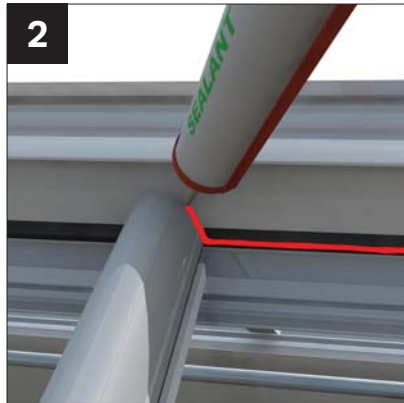

2

MS Polymer sealant only on Self cleaning glass

MS Polymer

Seal along the ridge baffle where it meets the glazing and over any bar where it meets the ridge.



3

Apply 2 generous beads of sealant to the underside of the external cover.

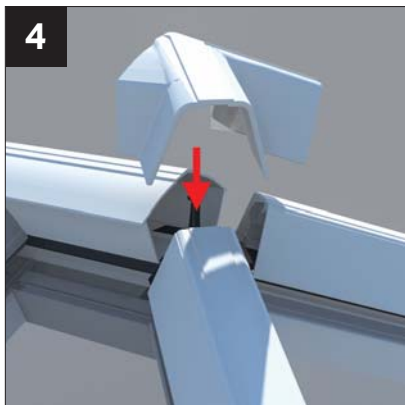

4

Press firmly down on the ridge end top cap until it clicks into position on the ridge end.

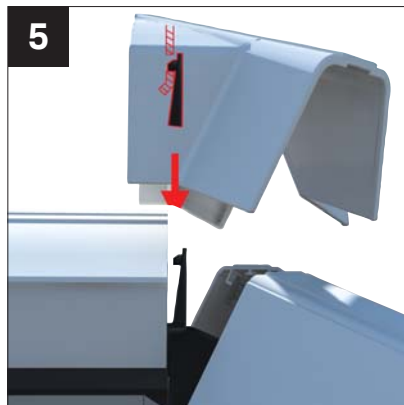

5

6

Fit end caps to bars and push in circular cover disk to finish.

INSTALLATION - PLASTIC INTERNAL COVER

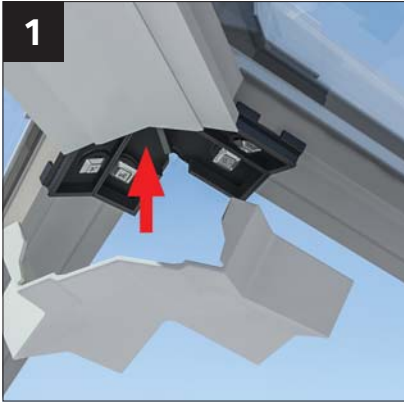

Fit the internal plastic cover by pushing up into position over the ridge and ridge end.

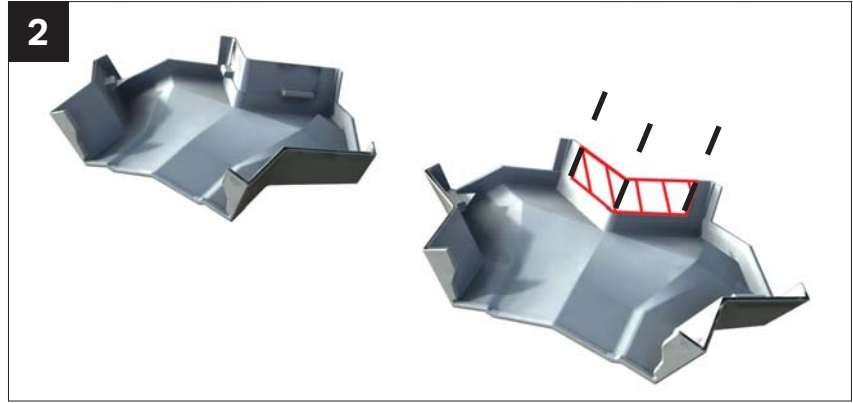

When a central transom between the hips is specified, the internal cover will need the highlighted section above removing. Using a hacksaw cut down the three dotted lines up to the lip. Then using pliers remove the section by bending back and forth. Tidy ends using a small file.

INSTALLATION - ALUMINIUM INTERNAL COVER (OPTIONAL ITEM)

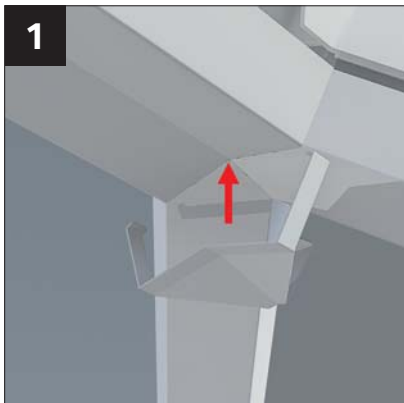

Clip fit into position the aluminium internal radius end cover trim.

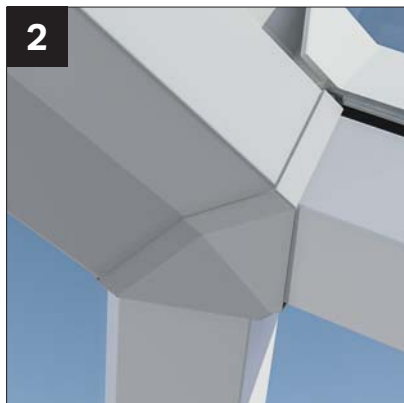

Clipped into final position.

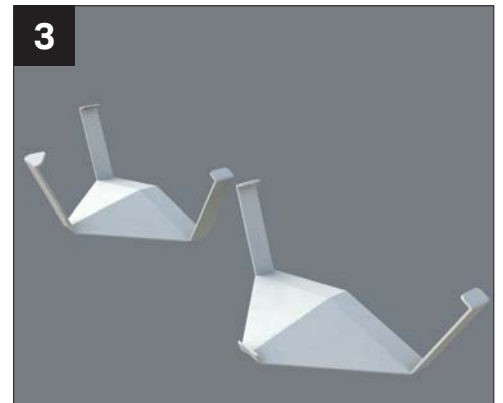

No central leg when roof has central transom between hip bars fitted.

PVCU ROOF VENT INSTALLATION - SASH

IMPORTANT

The roof vent opening sash must be glazed prior to fitting the vent to the conservatory roof. Leaving the recommended time (dependent on outside air temperature) for the sealant to cure.

Sealant curing time will vary depending upon the time of year and outside temperature prevailing, This could take up to 8 hours in cold conditions. This is critical when the sash is to be glazed with a sealed unit.

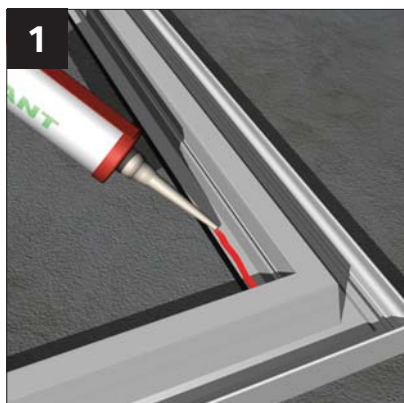

Remove the opening vent sash from the vent mainframe and lay the opening sash upside down on a flat surface. (Protect the surface to prevent damage to the sash). Run a continuous bead of appropriate sealant immediately behind the black co-extruded gasket, taking care to ensure a continuous run around the perimeter of the opening sash.

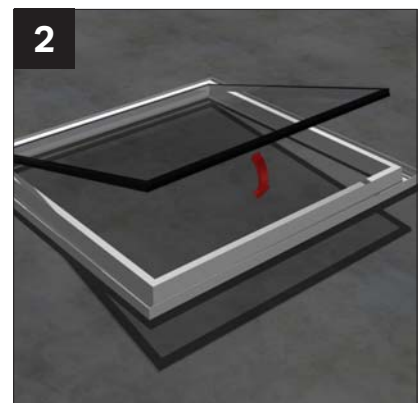

Remove all handling tape around the perimeter of the unit. When inserting the glazing ensure it is the correct way round and the external face is face down onto the continuous bead of sealant.

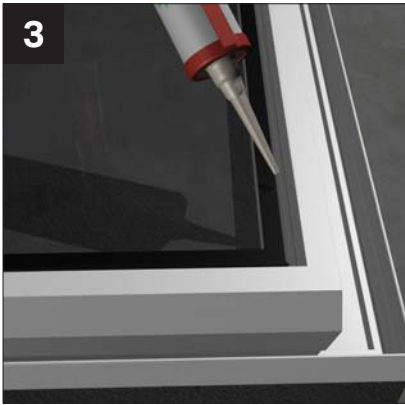

Seal the area around the full perimeter of the glazing.

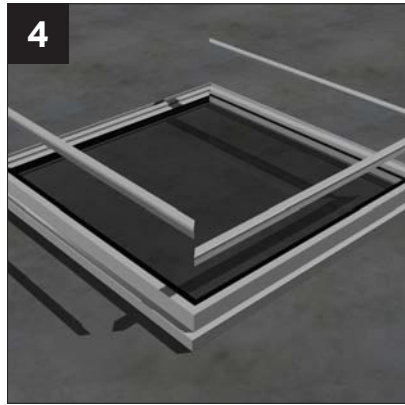

Re-fit the 'L' shaped serrated glazing beads to the opening sash. A small block of timber is useful to carefully knock in the beads.

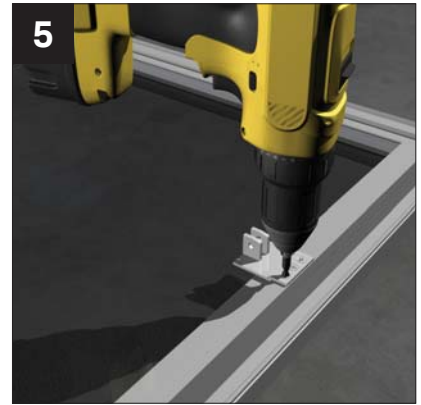

Centrally screw fix the sash bracket into the position shown above using the fixings provided. **Leave the sash to cure before fitting.**

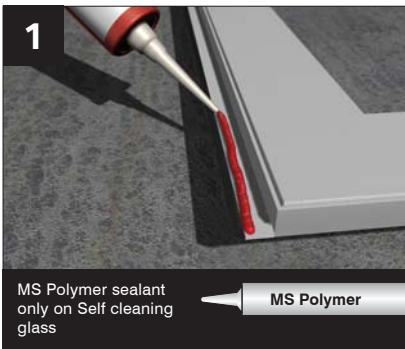

With the opening sash removed, lay the mainframe upside down on a smooth clean surface (protect the surface to prevent damage). Run a continuous bead of sealant (appropriate to the glass type) immediately behind the co-extruded gasket on the upper and lower legs.

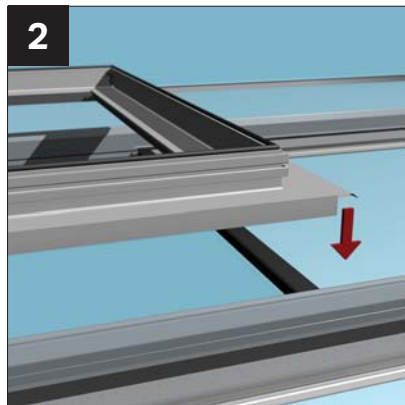

Carefully lower the frame into position on to the upper double glazed unit, making sure that any glazing tape has been removed from the edges of the sealed unit).

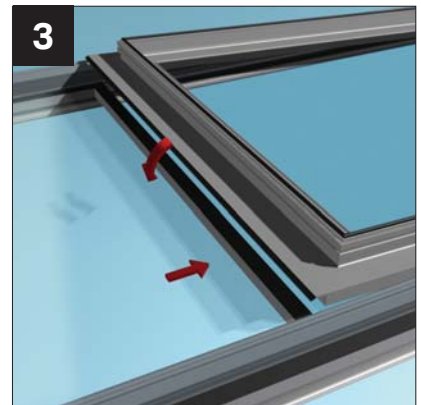

Lift the lower mainframe leg and offer into position the lower double glazed unit. Press down the mainframe firmly into position.



From inside, knock in the 'L' shaped serrated glazing beads to the top and bottom edges of the mainframe. NOTE: We recommend a second person to support the mainframe on the outside whilst carrying out this procedure.

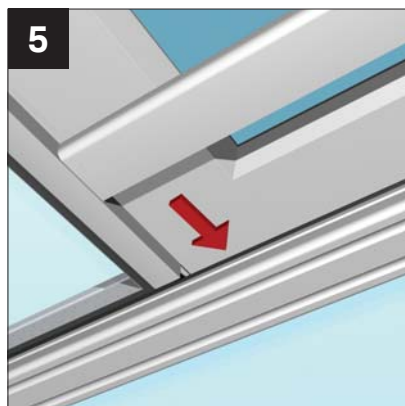

Down each side of the roof vent mainframe an 8mm thick PVCu architrave type packer is provided to suit the glazing thickness. Position as shown above.

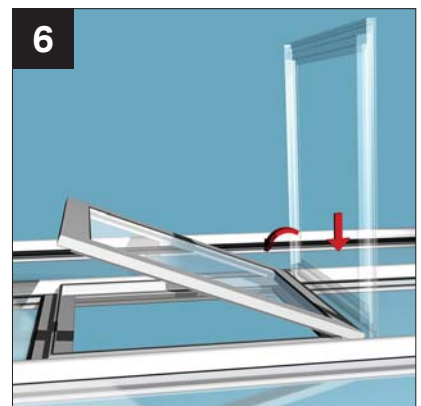

When the sealant on the mainframe has cured, re-fit the outer sash by holding vertically and re-engage on to the 'S' shaped hinge, before lowering into position. Refer to vent installation guide for further information about attaching the opening mechanism etc.

CLEANING AND MAINTENANCE - ALUMINIUM EXTERNAL

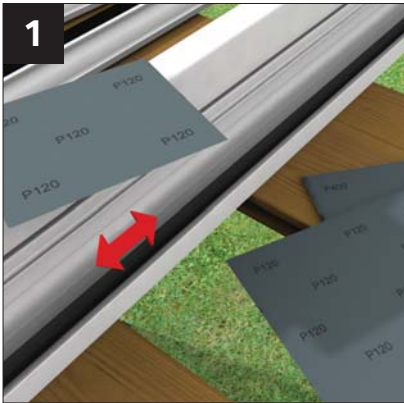

1 If surface damage is encountered, use 120-360 grit paper to prepare the surface. Wipe clean with white spirit.

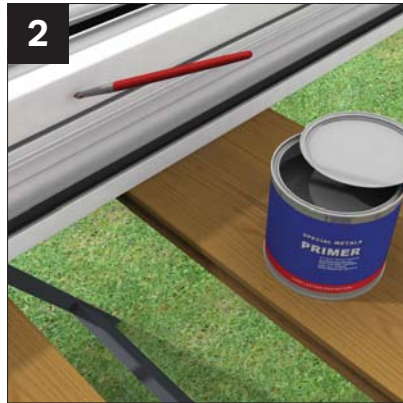

2 Ensure the surface is dry – apply a thin primer coat using a fine brush.



3 Finally, apply an air drying top coat with a fine brush.

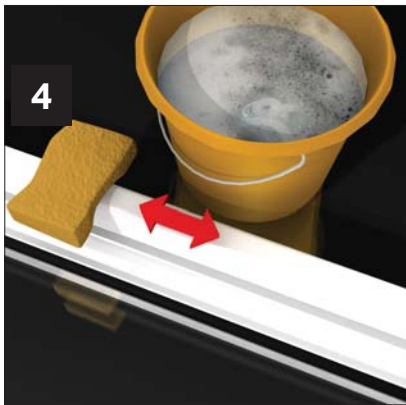

4 General cleaning can be undertaken by a wash with warm soapy water.

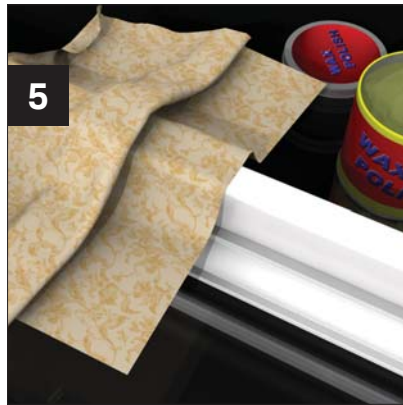

5 For added protection, a wax polish can be applied up to twice per year – follow the polish manufacturer's instructions carefully.

PLEASE PASS TO HOMEOWNER

It should be noted that polyester powder coatings are not maintenance free – the extent of cleaning depends upon the local environment and on the attitude of the building owner. Think cars here...if the building owner wants a finish like that, more regular cleaning is needed. All paints will 'chalk' to some extent and there will be a reduction in gloss level over time – this can be restored.

Only access roofs safely and using appropriate access equipment

Date: / /

